

Measuring current and resistance

Student Name \_\_\_\_\_

Key

Date \_\_\_\_\_

**Measuring current:** The simplest current measurements are made using an induction ammeter that is either clipped around the wire or placed onto the wire. Current flow is the same through any part of a series circuit. It divides into the branches of a parallel circuit with each branch having the same current flow all along that part of the circuit.

Connect the induction ammeter to the circuit by drawing a circle at the point where the measurement should be made, and numbering the circle for each check as indicated. Assume that each light has the same resistance and draws 2 amps. Do not open or close the switches.

1. Current flow from the battery; it should be 4 A. If the upper switch was closed, it should read 6 A.
2. Current flow from the fuse; it should be 4 A.
3. Current flow through the upper light; it should be 0 A.
4. Current flow through the lower lights; it should be 4 A.

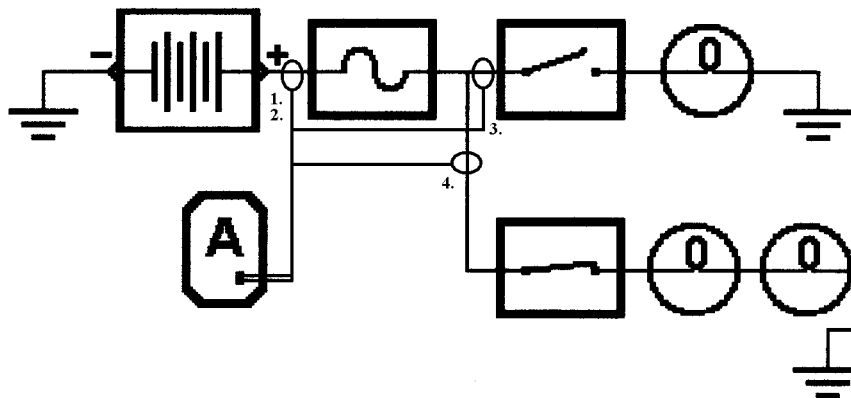

**Measuring resistance:** Resistance measurements are made using an ohmmeter, but they must never be connected to a circuit with electrical power. The two leads from the ohmmeter are connected to the two ends of the circuit being tested.

1. Connect the ohmmeter to measure the resistance of the solenoid coil. Let's say this coil has a resistance of 24 Ω, and the specification is 20 to 30 Ω.

This coil should be good/bad (circle one).

2. Reverse the two leads; the resistance should be lower Ω.

3. Check for a ground by moving one of ohmmeter leads to the mounting bracket. The resistance should be 0 Ω.

