

Compressor Clutch Circuit, Voltage Checks, Chapter 14

Student Name _____

KEY

Date _____

You are checking the voltage at various points through this compressor clutch circuit with the control switch in different positions. Each check point is indicated by a letter A through N.

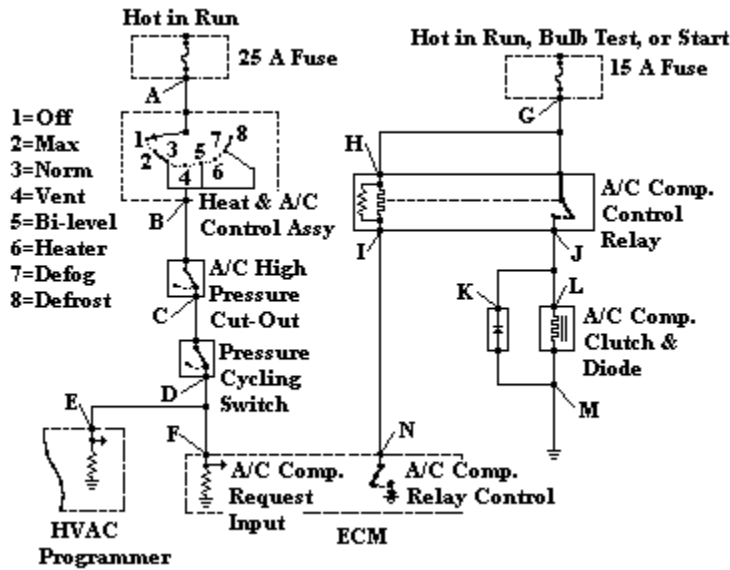

Indicate the

voltage that should be at each of the check points (Key On, Engine Off).

Control	Checking Points													
Switch	A	B	C	D	E	F	G	H	I	J	K	L	M	N
Off - 1														
Norm-3														
Vent-4														

Indicate the voltage that should be at each of the check points (Key On, Engine Running).

Control	Checking Points													
Switch	A	B	C	D	E	F	G	H	I	J	K	L	M	N
Off - 1	12.5						12.5	12.5	12.5					12.5
Norm-3	12.5	12.5	12.5	12.5	12.5	12.5	12.5	12.5	12.5					12.5
Vent-4	12.5						12.5	12.5	12.5					12.5

Indicate the voltage that should be at each of the check points (Key On, Engine Running, A/C requested).

Control	Checking Points													
Switch	A	B	C	D	E	F	G	H	I	J	K	L	M	N
Off - 1	12.5						12.5	12.5	12.5					12.5
Norm-3	12.5	12.5	12.5	12.5	12.5	12.5	12.5	12.5	6	12.5	12.5	12.5	0	6
Vent-4	12.5						12.5	12.5	12.5					12.5

Note to instructor: Without service information, the actual voltages are guesswork. There is also a question on when some of the terminals are turned on. B+ could be used in place of 12.5. Also, there could be an allowance for 0.1V drop per connection.